

SYSTEM.SCH

AUDIOSCOPE
MODEL 3211
PPM/VU LEVEL METER.

SYSTEM

RELEASE 1.0

| | | |
|-----------------------------------|------------------------------|---------------|
| AUDIOSCOPE | | |
| . MODEL 3211 | | |
| . LEVEL METER. | | |
| . HARDWARE REVISION | | |
| . MARK 3. | | |
| Title | | |
| AUDIOSCOPE MODEL 3211 LEVEL METER | | |
| Size | Document Number | Rev |
| A3 | D:\ORCAD\SHEET\3211\3211.SCH | 1.0 |
| Date: | Thursday, May 22, 2003 | Sheet 1 of 12 |

BLOCK DIAGRAM.



BLOCK

POWER.SCH



POWER

KEYBOARD.SCH



KEYBOARD

LOG. SCALE GENERATOR.



LOGSCALE

INPUT CONNECTORS.



INPUTS

MOTHER BOARD LOGIC



LOGI3211

ADC CONVERTER, DIGITAL MPX.



ADC

SPOT MPX.



SPOT

HISTOGRAM GENERATOR



HISTOGR

SCALE & GRATICULE GENERATOR.



SCALEGEN

UPPER & LOWER ROWS GENERATOR.



ROWSGEN

BAR ERASER & OVLD POINT SELECTOR.



ERASER

| | | | |
|-----------------------------------|--------------------------------|-------|--------|
| AUDIOSCOPE | | | |
| Title | | | |
| AUDIOSCOPE 2813 SPECTRUM ANALYSER | | | |
| Size | Document Number | Rev | |
| A3 | D:\ORCAD\SHEET\2813\SYSTEM.SCH | 5.0 | |
| Date: | Thursday, May 22, 2003 | Sheet | 2 of 0 |

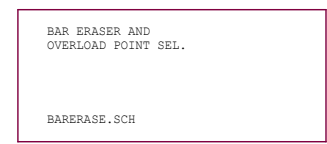
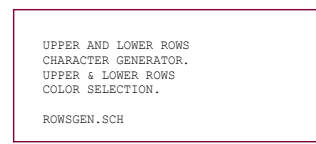
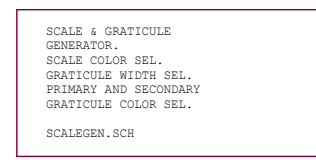
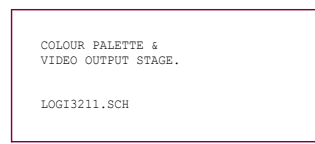
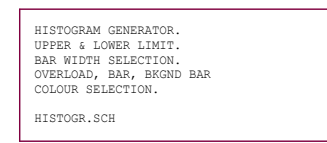
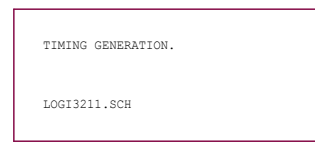
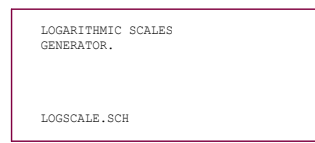
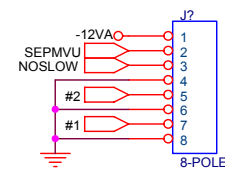
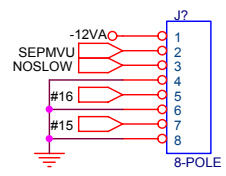
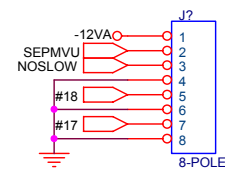
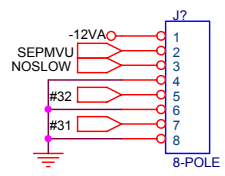
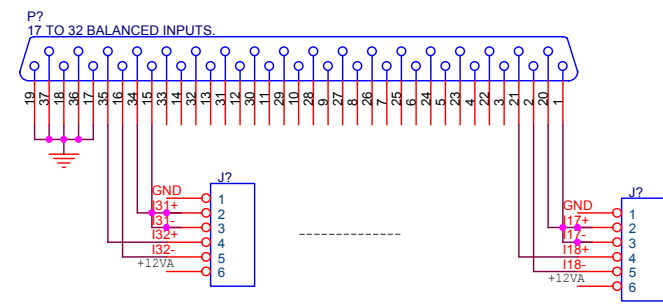
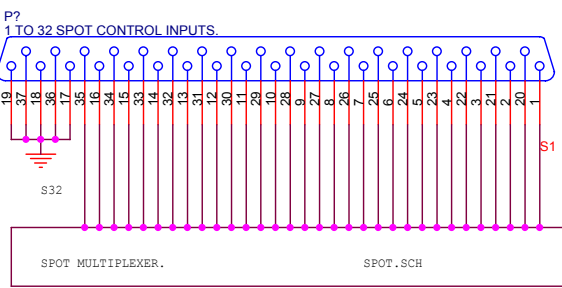

POWER
SUPPLY
CIRCUITS
& HEAT SINKS.

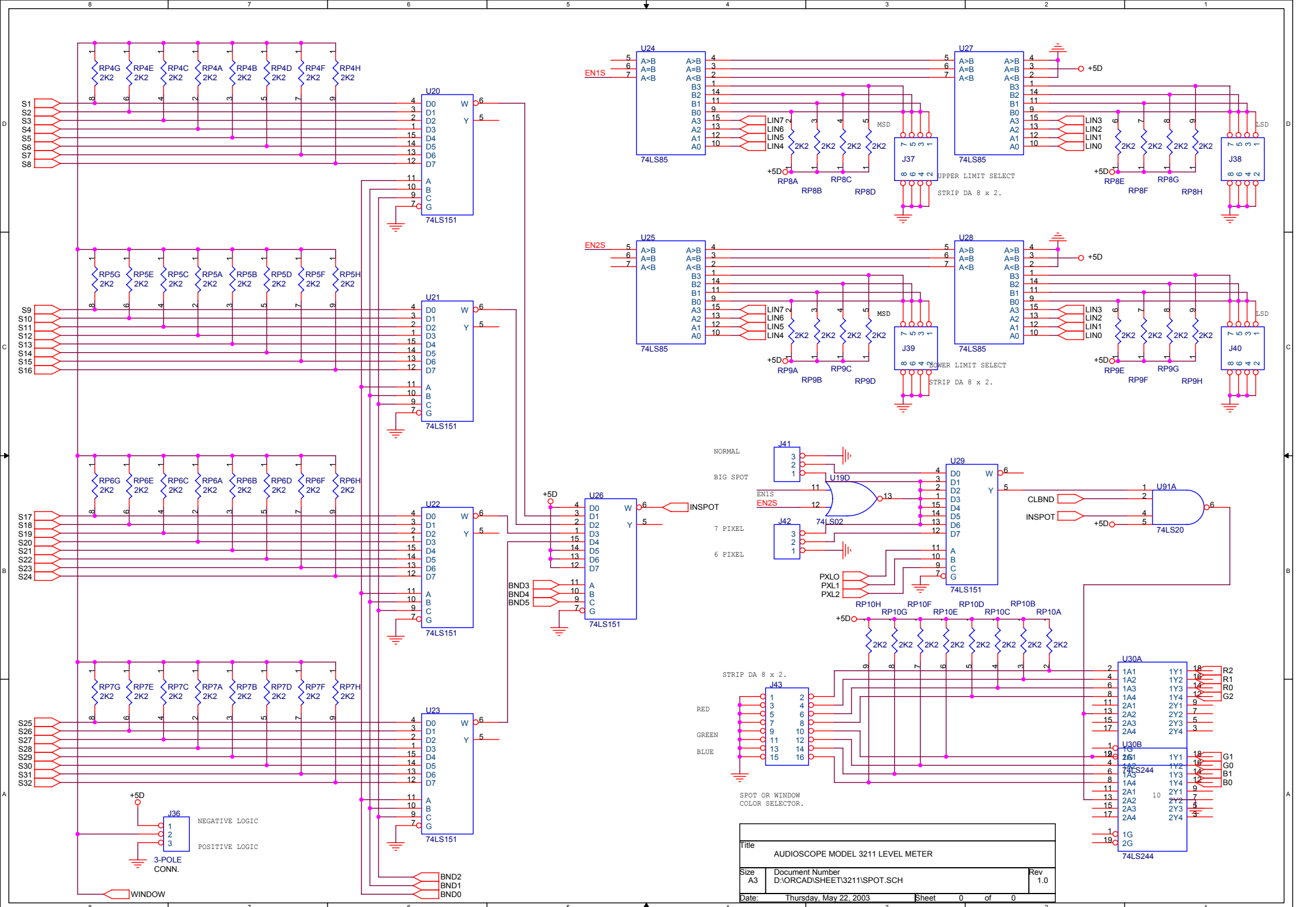

| | | |
|-----------------------------------|------------------------------|--------------|
| Title | | |
| AUDIOSCOPE MODEL 3211 LEVEL METER | | |
| Size | Document Number | Rev |
| A3 | D:\ORCAD\SHEET\3211\SPOT.SCH | 1.0 |
| Date: | Thursday, May 22, 2003 | Sheet 0 of 0 |

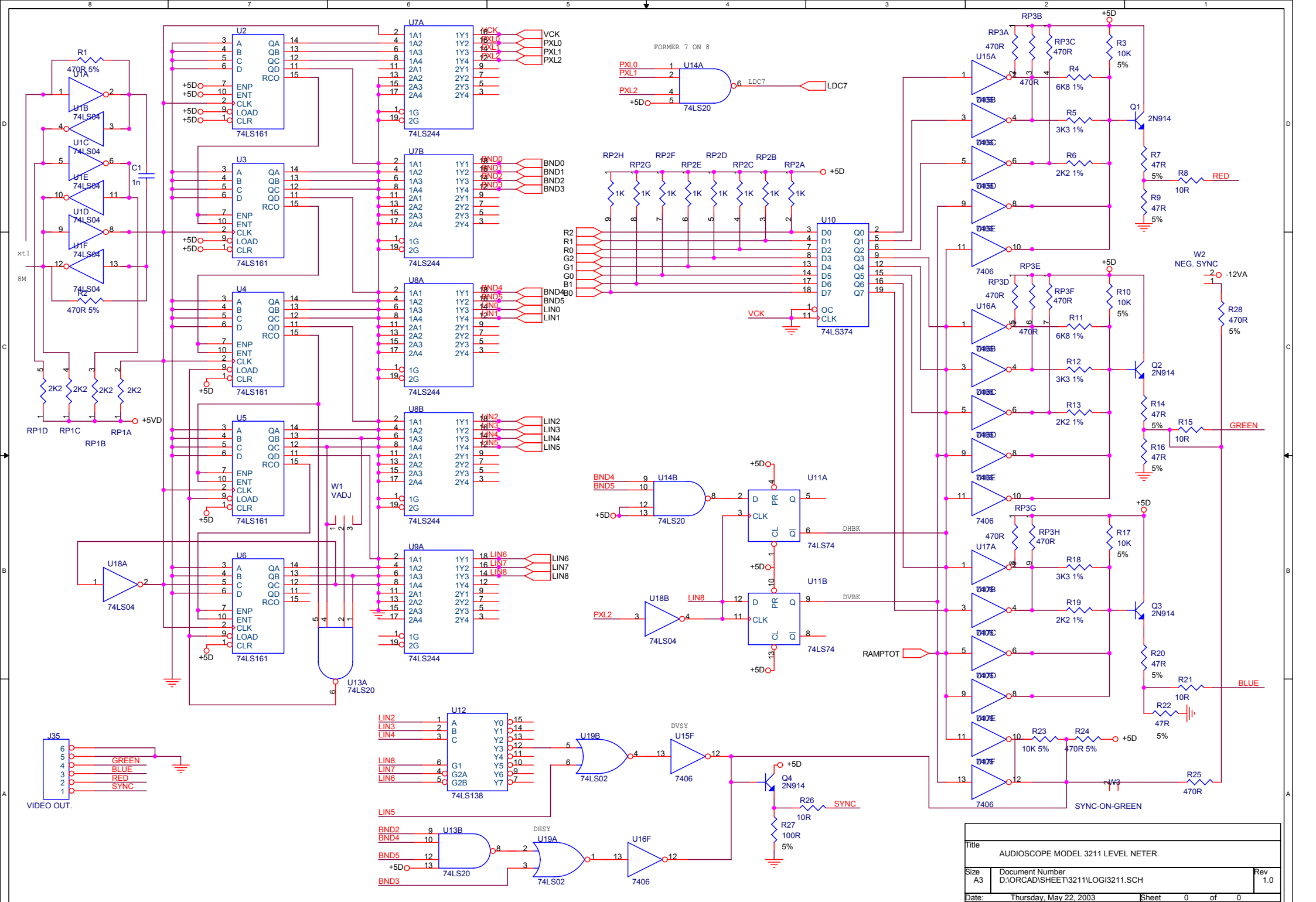

| | | |
|------------------------------------|----------------------------------|--------------|
| Title | | |
| AUDIOSCOPE MODEL 3211 LEVEL METER. | | |
| Size | Document Number | Rev |
| A3 | D:\ORCAD\SHEET\3211\LOGI3211.SCH | 1.0 |
| Date: | Thursday, May 22, 2003 | Sheet 0 of 0 |

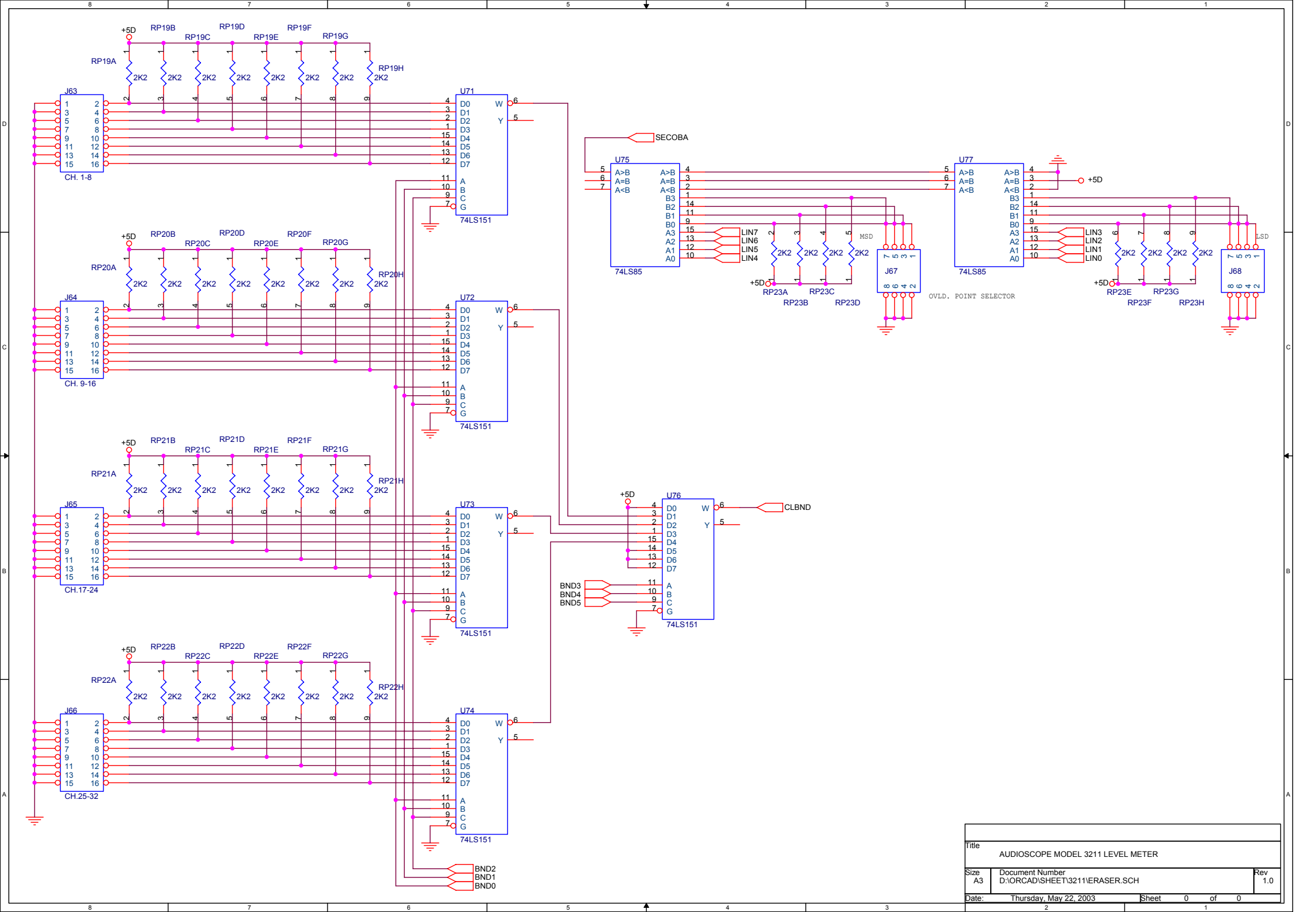

| | | |
|-----------------------------------|--------------------------------|--------------|
| Title | | |
| AUDIOSCOPE MODEL 3211 LEVEL METER | | |
| Size | Document Number | Rev |
| A3 | D:\ORCAD\SHEET\3211\ERASER.SCH | 1.0 |
| Date: | Thursday, May 22, 2003 | Sheet 0 of 0 |

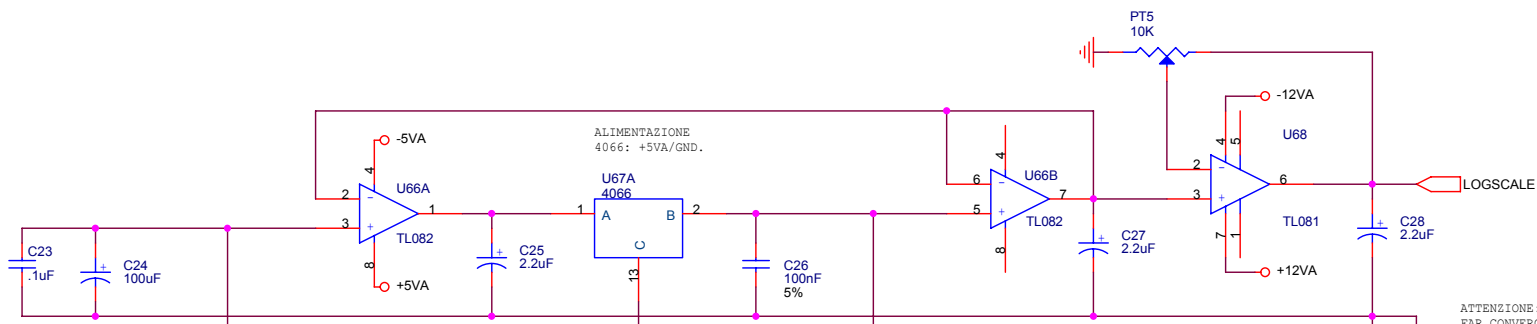

ATTENZIONE:
 FAR CONVERGERE
 IN UN UNICO PUNTO
 TUTTI QUESTI COLLEGAMENTI
 DI MASSA.

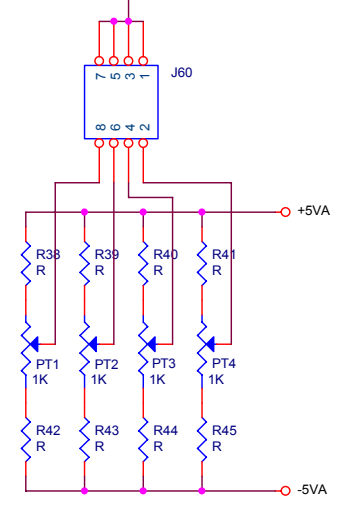

RAMPTOT

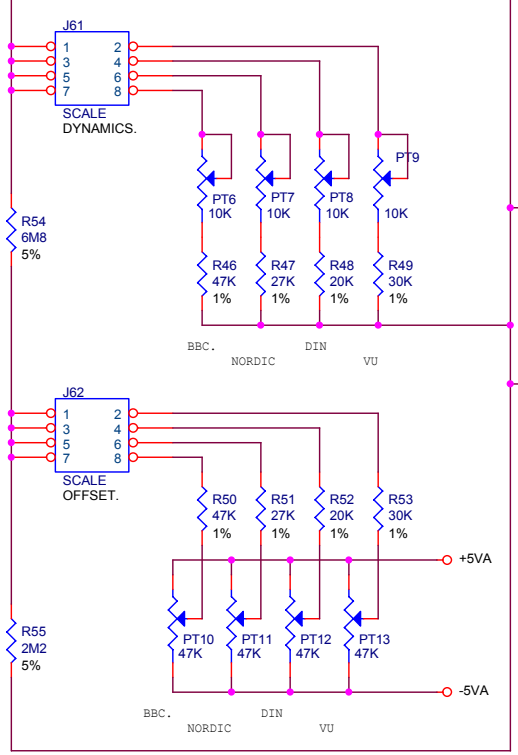

REGOLATORI IN PIEDI
 SENZA RADIATORE.

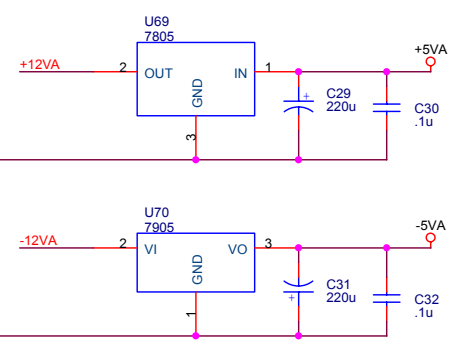

| | | |
|------------------------------------|----------------------------------|--------------|
| Title | | |
| AUDIOSCOPE MODEL 3211 LEVEL METER. | | |
| Size | Document Number | Rev |
| A3 | D:\ORCAD\SHEET\3211\LOGSCALE.SCH | 1.0 |
| Date: | Thursday, May 22, 2003 | Sheet 0 of 0 |

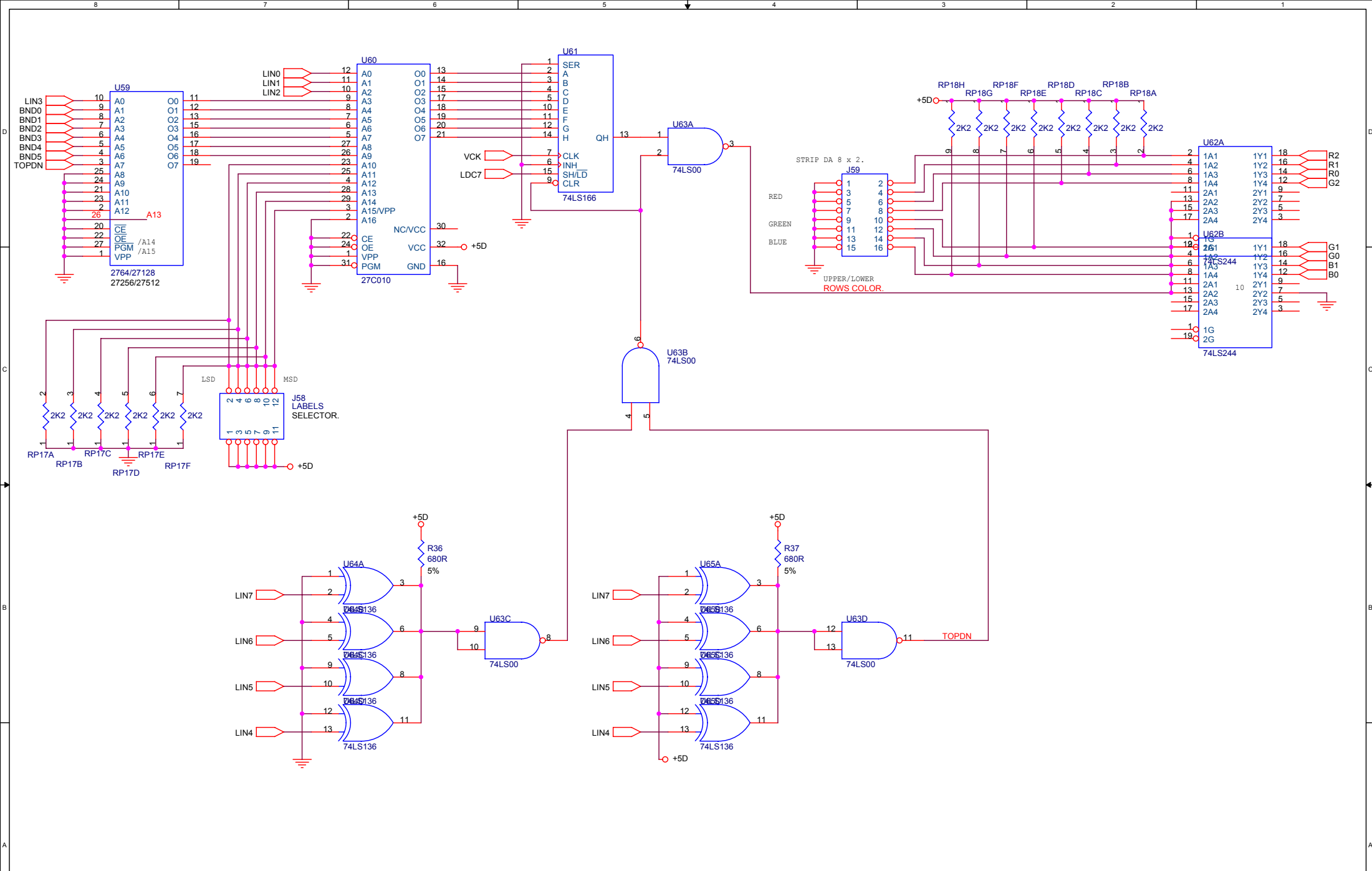

| | | |
|-----------------------------------|---------------------------------|--------------|
| Title | | |
| AUDIOSCOPE MODEL 3211 LEVEL METER | | |
| Size | Document Number | Rev |
| A3 | D:\ORCAD\SHEET\3211\ROWSGEN.SCH | 1.0 |
| Date: | Thursday, May 22, 2003 | Sheet 0 of 0 |

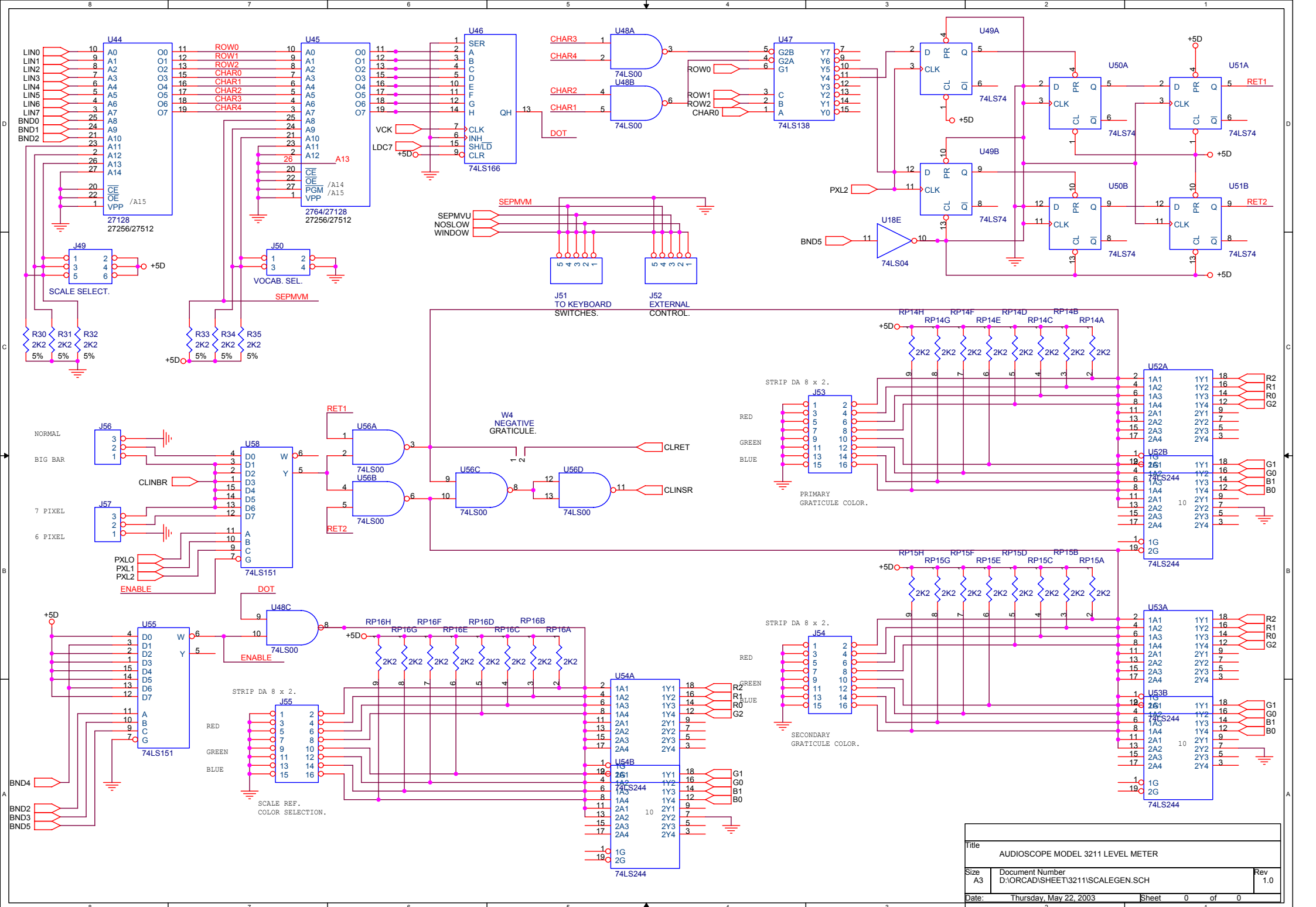

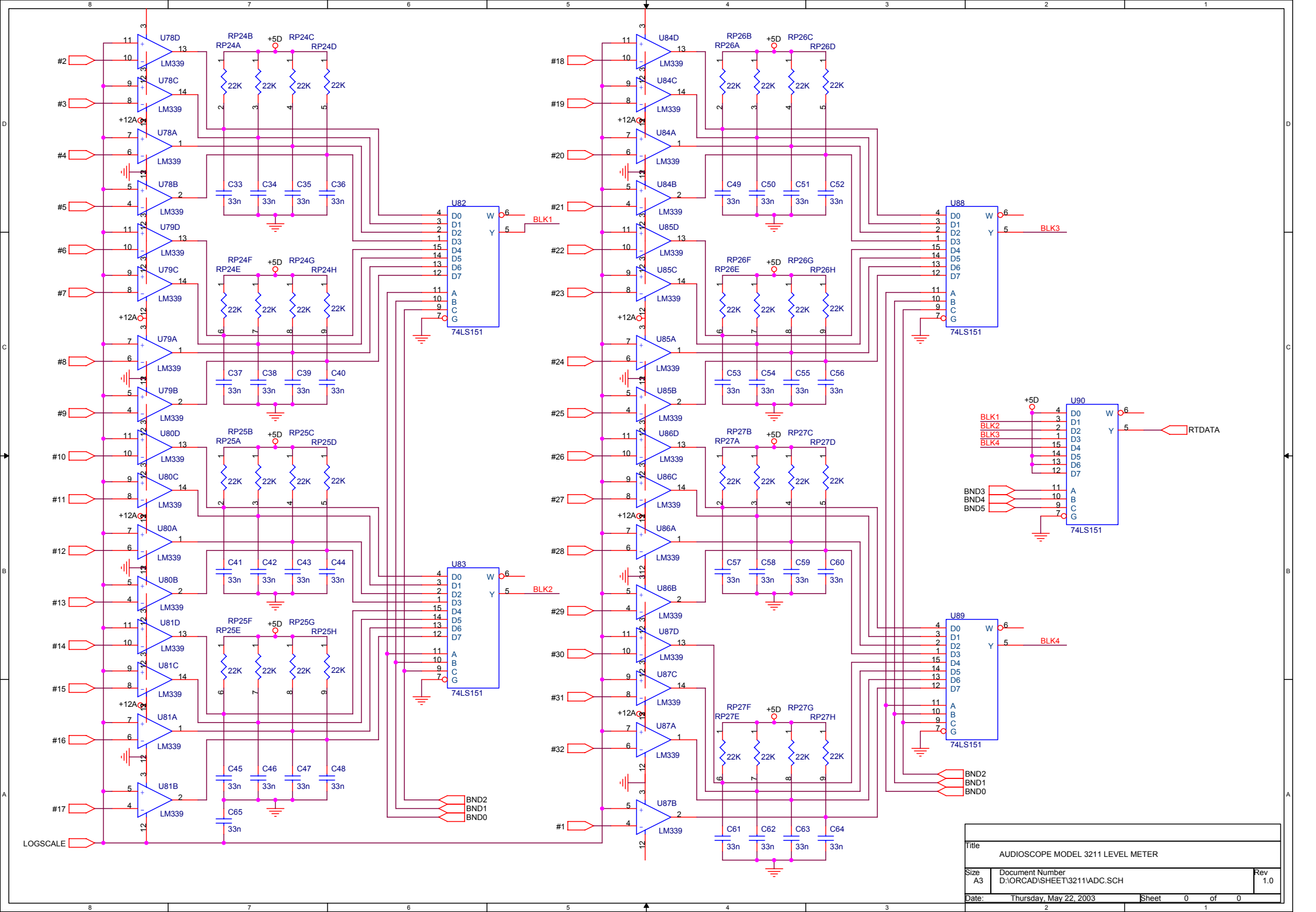

| | | |
|-----------------------------------|-----------------------------|--------------|
| Title | | |
| AUDIOSCOPE MODEL 3211 LEVEL METER | | |
| Size | Document Number | Rev |
| A3 | D:\ORCAD\SHEET\3211\ADC.SCH | 1.0 |
| Date: | Thursday, May 22, 2003 | Sheet 0 of 0 |

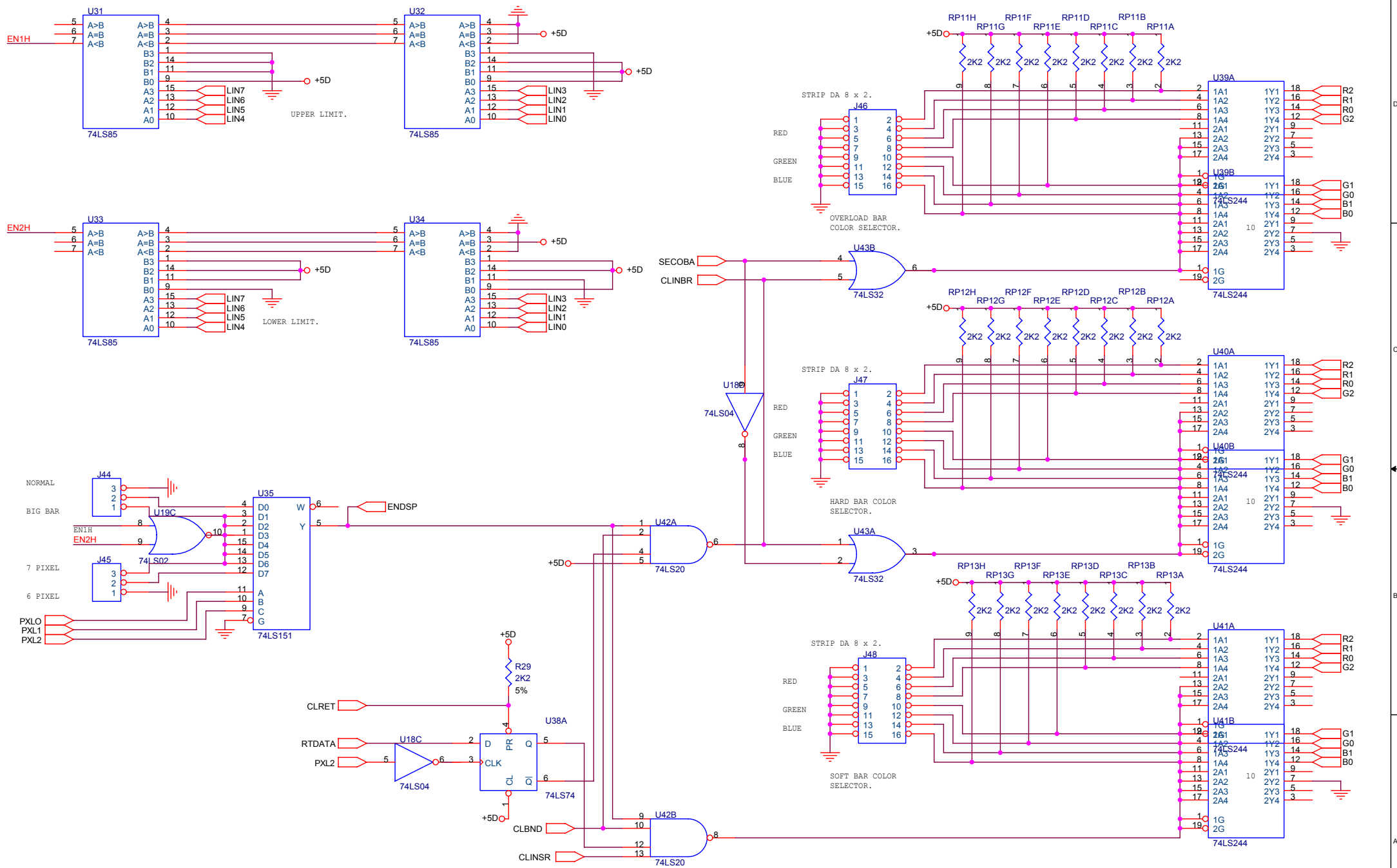

P2
1 TO 32 SPOT CONTROL INPUTS.

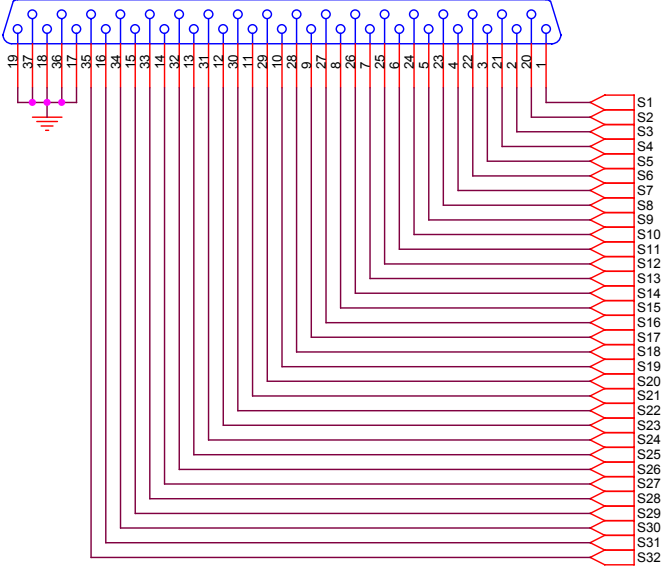

P1
17 TO 32 BALANCED INPUTS.

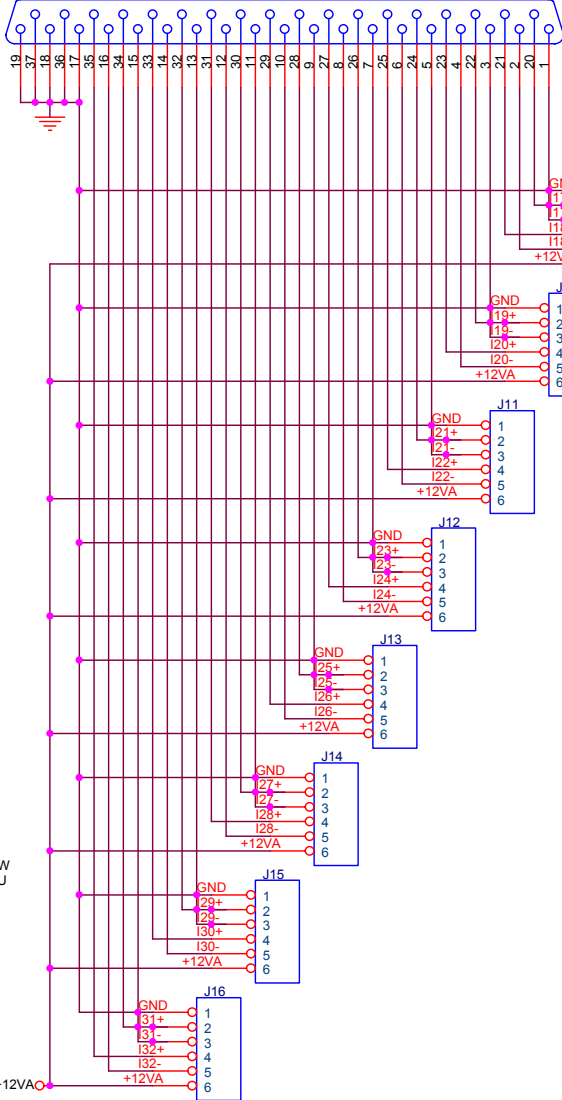

P3
1 TO 16 BALANCED INPUTS.

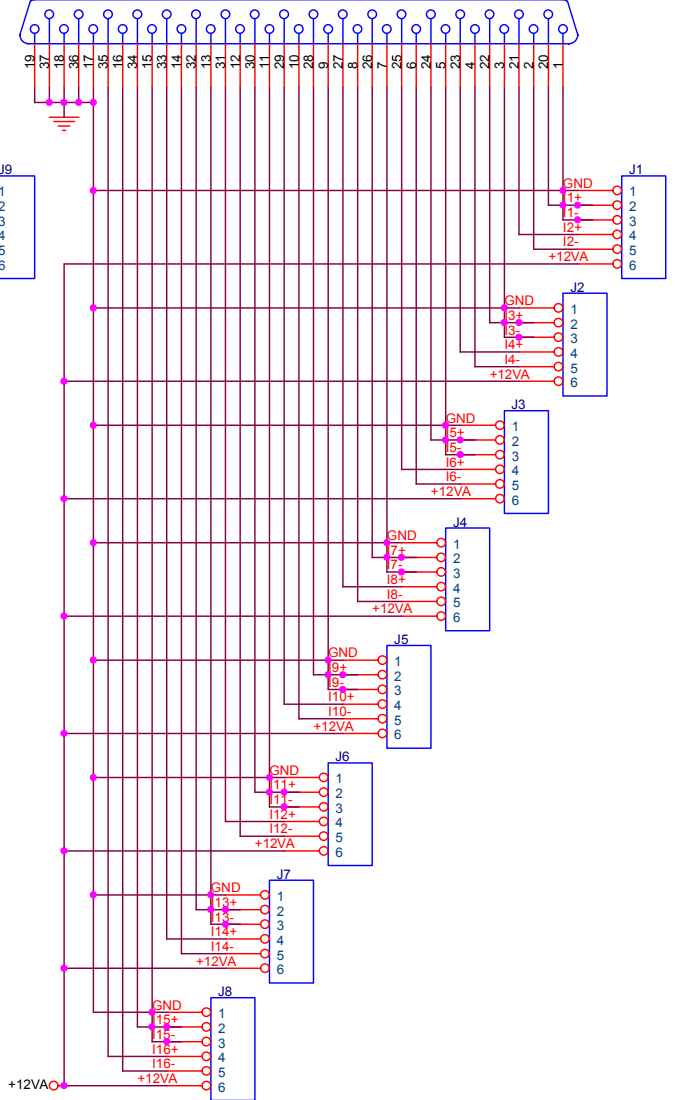

NOSLOW
SEPMVU
-12VA

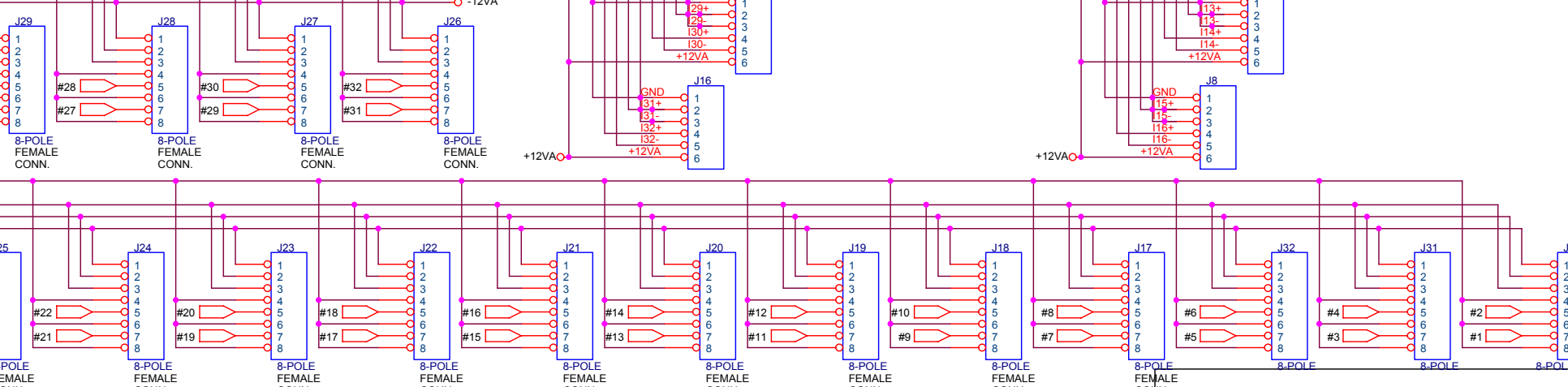

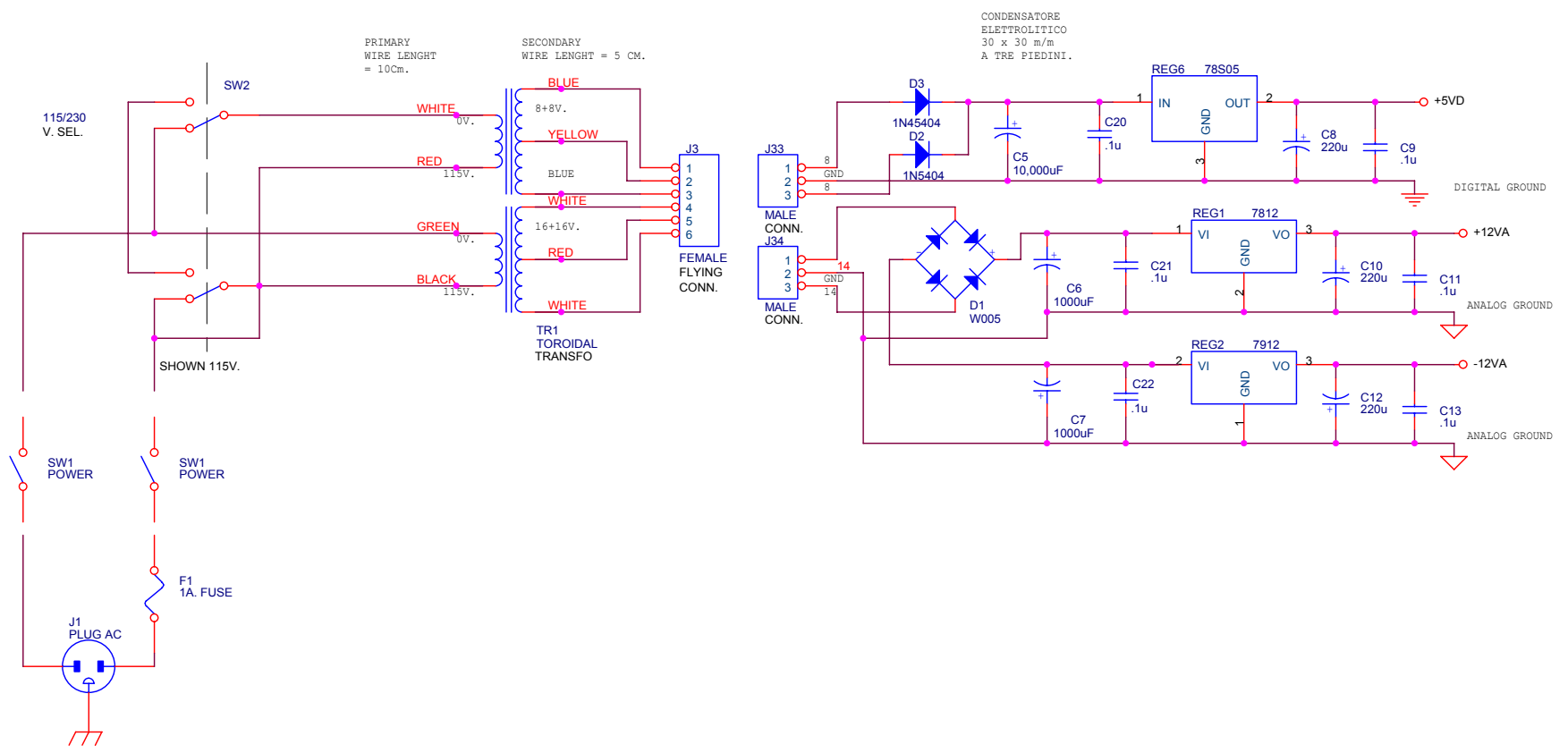

PRIMARY WIRE LENGHT = 10cm.
SECONDARY WIRE LENGHT = 5 CM.

CONDENSATORE ELETTROLITICO
30 x 30 m/m
A TRE PIEDINI.

**POWER SUPPLY BOARD
LAST COMPONENT USED**



| | | |
|---|--|------------|
| AUDIOSCOPE 3211 POWER SUPPLY | | |
| +/- 12V. ANALOG POWER SUPPLY. | | |
| + 5V. DIGITAL POWER SUPPLY. | | |
| Title AUDIOSCOPE 3211 PPM/VU LEVEL METER | | |
| Size A3 | Document Number D:\ORCAD\SHEET\3211\POWER.SCH | Rev 1.0 |
| Date: Thursday, May 22, 2003 | Sheet 2 | of 12 |

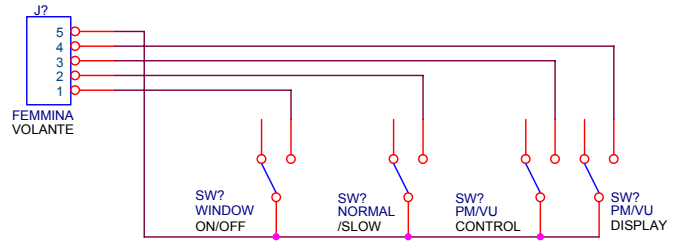

| | | |
|--|----------------------------------|---------------|
| . AUDIOSCOPE | | |
| . KEYBOARD. | | |
| Title | | |
| AUDIOSCOPE MODEL 3211 PPM/VU LEVEL METER | | |
| Size | Document Number | Rev |
| A3 | D:\ORCAD\SHEET\3211\KEYBOARD.SCH | 1.0 |
| Date: | Thursday, May 22, 2003 | Sheet 3 of 12 |

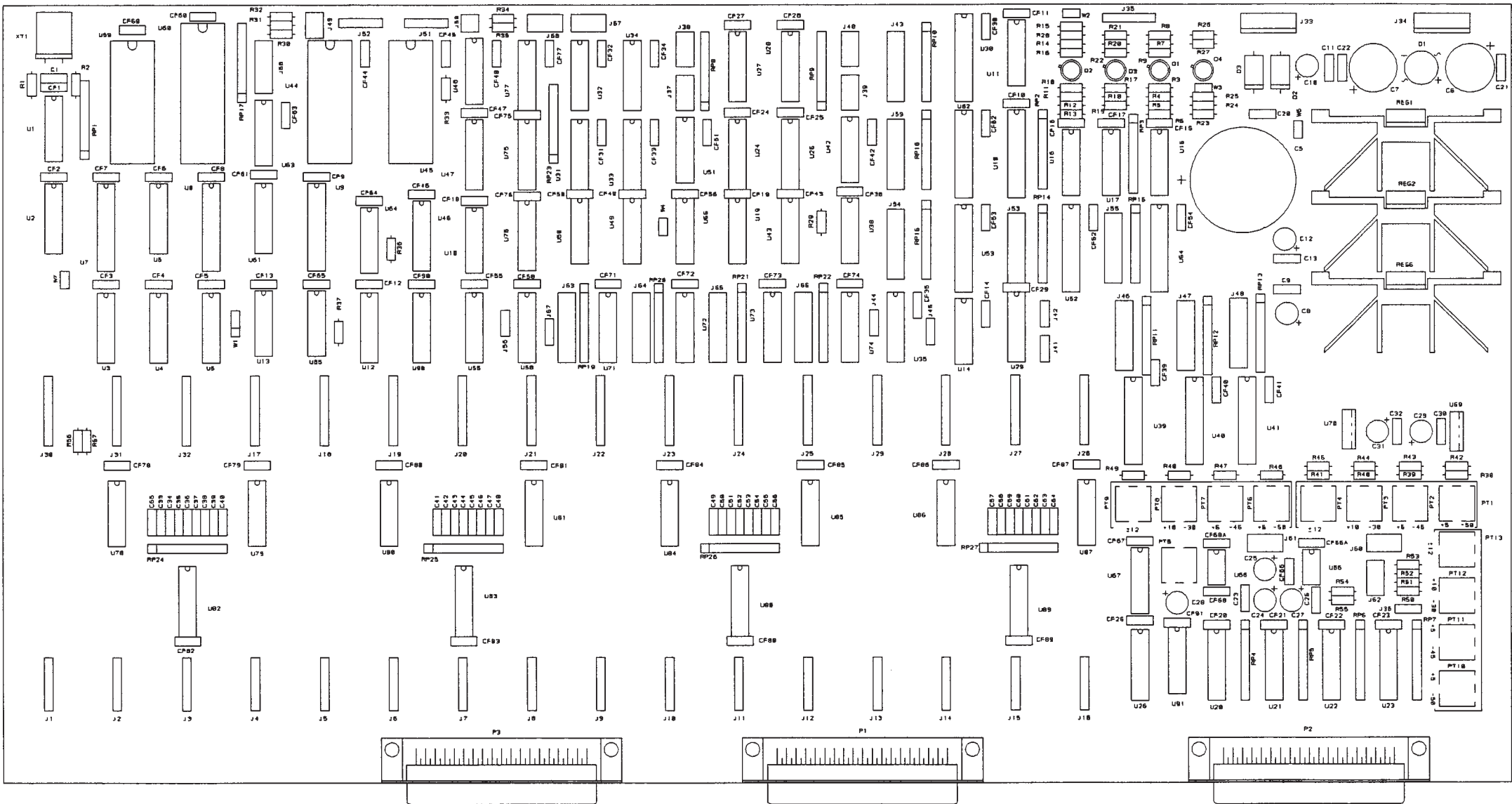

DOUBLE SCALE SHOWN.

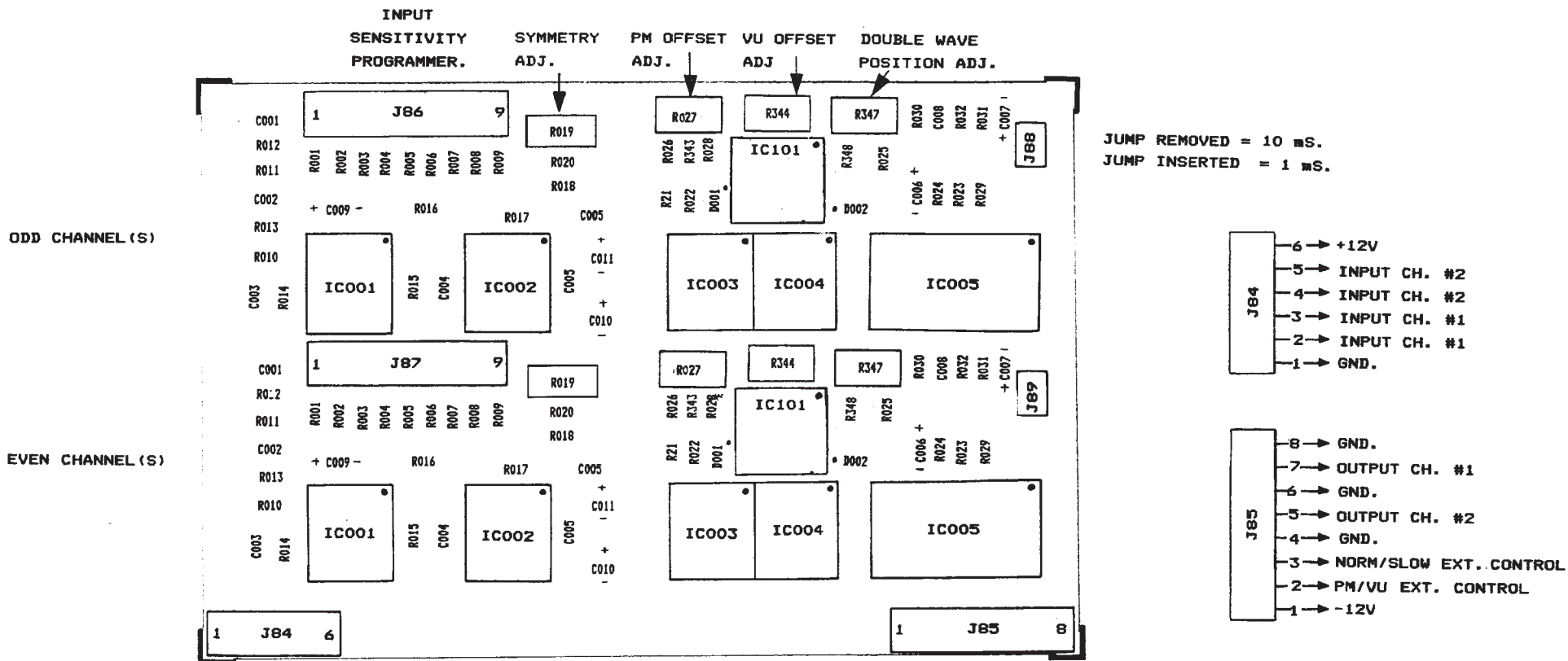

A2

